

Specification Sheet

UNI120 Anchor Seal

UNI120 Anchor seal features a polycarbonate body and is used in conjunction with a **0.9mm diameter** stainless steel or galvanised sealing wire. After inserting the sealing wire into the holes, the **anchor locking mechanism** is pushed into body to secure the seal.

The Anchor seal can be **laser-marked** with your company name and 8-digit numbering - optional **duplicate number** can be printed on the **anchor itself**, for enhanced security level. The Anchor seal can be supplied alongside **pre-cut sealing wire** in any length, or reels of wire for varied application.

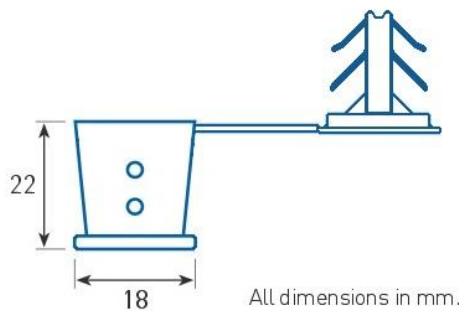

Applications

Utility meters (gas, electrical and water meters), as well as for applications in petroleum, taxi, telecommunication and postal sectors.

Size Guide

22x18mm body. Variable length sealing wire.

Technical specs

Nylon operating temperature: -40°C to +120°C
Tensile strength: 30KgF

Packaging

	Carton	Master Carton
Quantity	1,000pcs	5,000pcs
Carton Dimensions	23x40x22cm	39x23x73cm
Box Weight	3kg	15kg
Pallet Info	100x120x150cm 70,000pcs	100x120x155cm 100,000pcs



Available Colours

Translucent red, blue, yellow, green, orange, white.

Material

Polycarbonate (PC) and steel sealing wire

Customisation Options

Company marking, 8-digit sequential numbering. Optional duplicate number printing on anchor for additional tamper proofing. Laser-printed.